

DIO-3216B

Digital I/O Card

User's Manual (V1.0)

健昇科技股份有限公司

JS AUTOMATION CORP.

台北縣汐止市中興路 100 號 6 樓

6F, No. 100, Chungshin Rd.

Shitsu, Taipei, Taiwan, R.O.C.

TEL : 886-2-2647-6936

FAX : 886-2-2647-6940

<http://www.automation.com.tw>

E-mail : control.cards@automation.com.tw

Correction record

Version	Record
1.0	New

Contents

1.	Forward.....	4
2.	Features.....	5
2.1	Main card.....	5
2.2	Din rail mounted wiring board.....	5
3.	Specifications.....	6
3.1	DIO-3216B Main card.....	6
3.2	Din rail mounted wiring board.....	8
4.	Layout and dimensions.....	9
4.1	DIO-3216B Main card.....	9
4.2	ADP-9201DIN Din rail mounted wiring board.....	9
5.	PIN definitions.....	10
5.1	Pin definitions for JM1 connector.....	10
5.2	Pin definitions for JM2 connector.....	10
6.	I/O interface diagram.....	11
6.1	Input diagram.....	11
6.2	Output diagram (On main card).....	11
7.	Hardware settings.....	12
7.1	CARD ID setting.....	12
7.2	Jumper setting.....	12
8.	Applications.....	13
9.	Ordering information.....	14

Notes on hardware installation

Please follow step by step as you are installing the control cards.

1. Be sure your system is power off.
2. Be sure your external power supply for the wiring board is power off.
3. Plug your control card in slot, and make sure the golden fingers are put in right contacts.
4. Fasten the screw to fix the card.
5. Connect the cable between the card and wiring board.
6. Connect the external power supply for the wiring board.
7. Recheck everything is OK before system power on.
8. External power on.

Congratulation! You have it.

For more detail of step by step installation guide, please refer the file “installation.pdf “ on the CD come with the product or register as a member of our user’s club at:

<http://automation.com.tw/>

to download the complementary documents.

Warning:

Some computer BIOS has “Auto detect DIMM/PCI clock” option, be sure to switch to “DISABLE” else in some cases the PCI add on cards will not be detected by windows at cold start.

1. Forward

Thank you for your selection of JAC's product DIO-3216B 16 inputs and 16 outputs DIGITAL I/O card for industrial PC. In the field of industrial control, digital I/O is generally controlled under a microprocessor and owing to their specific consideration of industrial environment, it is quite different from the laboratory requirement.

This card is a FPGA based design and will be a replacement of the older DIO3216 and Dio3216A. Our experience in the noise immunity makes this card very stable in the noisy environment and you don't worry about computer down by external noise. We wish the card that will be helpful to your project.

Other DIO series products:

- DIO-9201 16 channel input and 16 channel output isolated digital I/O card (ISA bus)
- DIO-2232 32 channel input and 32 channel output isolated digital I/O card (ISA bus)
- DIO-2248 48 channel input and 16 channel output isolated digital I/O card (ISA bus)
- DIO-2264 64 channel input isolated digital I/O card (ISA bus)
- DIO-3206 48 channel TTL digital I/O Card (PCI bus)
- DIO-3208B 8 channel input and 8 channel relay output isolated digital I/O card (PCI bus)
- DIO-3217 16 channel input and 16 channel output isolated digital I/O card (PCI bus)
with multifunction timer/counter
- DIO-3232 32 channel input and 32 channel output isolated digital I/O card (PCI bus)
- DIO-3248 48 channel input and 16 channel output isolated digital I/O card (PCI bus)
- DIO-3264 64 channel input isolated digital I/O card (PCI bus)
- DIO-4264 64 TTL digital I/O PC-104 Module
- DIO-6208 8 channel input and 8 channel relay output isolated digital I/O PCI-104 Module
- DIO-6216 16 channel input and 16 channel relay output isolated digital I/O PCI-104 Module

Any comment is welcome,

please visit our website

[http:// www.automation.com.tw](http://www.automation.com.tw) for the up to date information.

2. Features

2.1 Main card

- 2.1.1 16 isolated DI and 16 isolated DO channels
- 2.1.2 High voltage isolation on all isolated channel (2500 Vac)
- 2.1.3 Programmable digital filter at 100Hz,200Hz,1KHz and no de-bounce for input
- 2.1.4 No output transition during start-up
- 2.1.5 Output status readback
- 2.1.6 External triggered interrupt (on IN00~IN07)
- 2.1.7 Keep output state after hot reset (jumper selectable)
- 2.1.8 Software key function

2.2 Din rail mounted wiring board

- 2.2.1 DIN rail wiring board with different output options
- 2.2.2 ADP-9201DIN Din rail mounted wiring board
- 2.2.3 JD50053 20P Din rail mounted dummy wiring board

3. **Specifications**

3.1 DIO-3216B Main card

Input Section

- 3.1.1 Input : 16 photo-isolated
- 3.1.2 ON state : 2.8Vdc(max) 4.5mA(min)
- 3.1.3 OFF state : 8Vdc(min) 3mA(max)
- 3.1.4 Switching speed : 10KHz max. (limit by photo coupler speed and debounce filter)
- 3.1.5 Interrupt at IN00 ~ IN07

Output Section

- 3.1.6 Output : 16 photo-isolated
- 3.1.7 Output range : Open collector 0 ~ 45 Vdc (on card)
- 3.1.8 Output rating : 3A @250Vac, 30Vdc (Relay)
 - 1A @ 24Vdc (P-MOS)
 - 2A @ 240Vac (SSR)
- 3.1.9 Sink current : 500mA(peak) per channel (on card)
- 3.1.10 Switching speed : 20KHz(max)(MOS out only)

Main Card General

3.1.11 Card ID : 4 bits

3.1.12 Insulation resistance : 100M Ohm (min) at 1000Vdc

3.1.13 Isolation voltage : 2500Vac 1Min

3.1.14 Connector : Two 20-pin male flat-cable connectors

3.1.15 Operation temperature : 0 to +70 degree C

3.1.16 Storage temperature : -20 to +80 degree C

3.1.17 Operation humidity : 5~95% RH, non-condensing

3.1.18 Dimensions : 130(W) * 102(H) mm , 5.12(W) * 4.02(H)in

3.2 Din rail mounted wiring board

ADP-9201DIN Din rail mounted wiring board

- 3.2.1 External Supply : DC 24V \pm 4V
- 3.2.2 Input : 8 with LED indicator
- 3.2.3 Output : ADP-9201DIN(R) : 8 relays (3A @250Vac, 3A @30Vdc) with LED indicator
ADP-9201DIN(S) : 8 SSR (2A @240Vac) with LED indicator
ADP-9201DIN(P) : 8 P-MOS (Source 1A @24Vdc) with LED indicator
- 3.2.4 Connector: One 20-pin male flat-cable connector
- 3.2.5 Operation Temperature: 0 to +70 degree C
- 3.2.6 Operation Humidity: RH5~95%, non-condensing
- 3.2.7 Dimension: ADP-9201DIN(R) / (P) : 86(W) * 103(L) *45(H)mm;
3.39(W)*4.06(L)*1.77(H)in
ADP-9201DIN(S) : 86(W) * 103(L) *50(H)mm
3.39(W)*4.06(L)*1.97(H)in

JD50053 20P Din rail mounted dummy wiring board

- 3.2.8 Dimension: 86(W)*79(L)*52(H)mm, 3.39(W)*3.11(L)*2.05(H)in

4. Layout and dimensions

4.1 DIO-3216B Main card

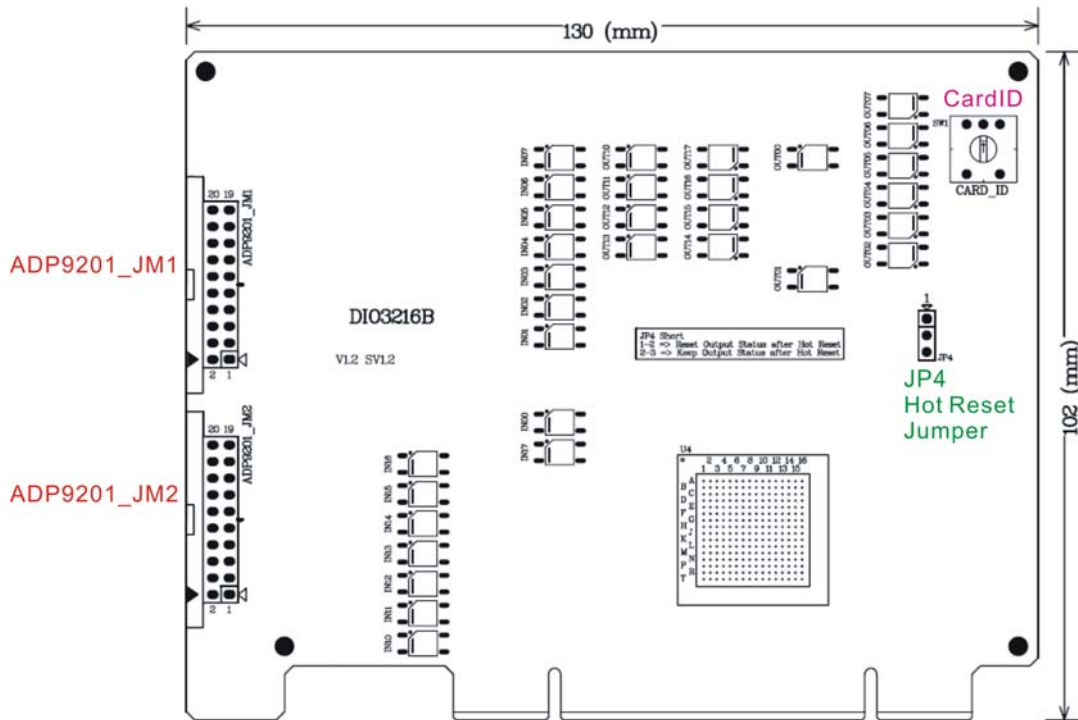

4.2 ADP-9201DIN Din rail mounted wiring board

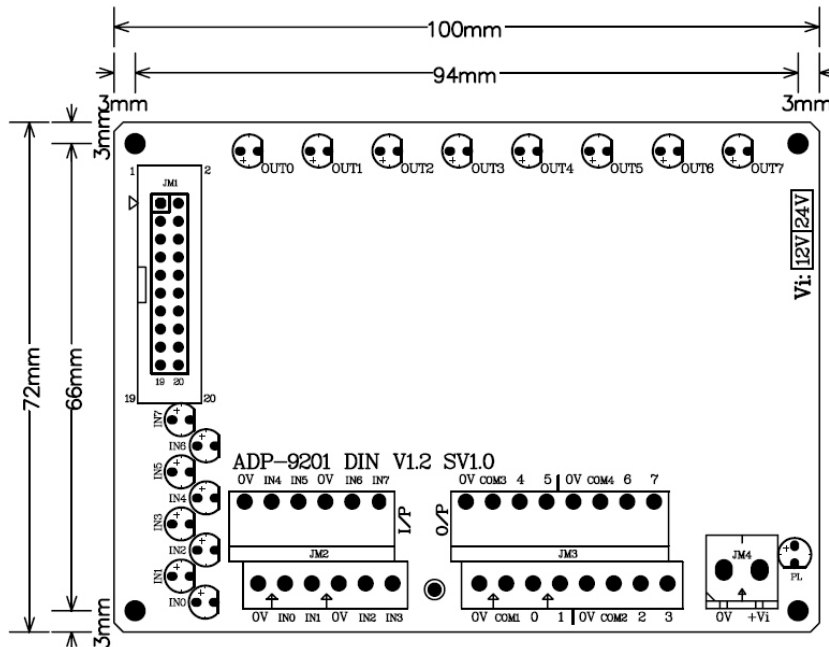

5. PIN definitions

5.1 Pin definitions for JM1 connector

PIN	Descriptions		PIN	Descriptions
1	EXT_IN00	EXT_IN00	2	EXT_OUT00
3	EXT_IN01	EXT_IN01	4	EXT_OUT01
5	EXT_IN02	EXT_IN02	6	EXT_OUT02
7	EXT_IN03	EXT_IN03	8	EXT_OUT03
9	EXT_IN04	EXT_IN04	10	EXT_OUT04
11	EXT_IN05	EXT_IN05	12	EXT_OUT05
13	EXT_IN06	EXT_IN06	14	EXT_OUT06
15	EXT_IN07	EXT_IN07	16	EXT_OUT07
17	EXTG	EXTG	18	EXTG
19	+24Ve	EXT +24Vin	20	+24Ve

5.2 Pin definitions for JM2 connector

PIN	Descriptions		PIN	Descriptions
1	EXT_IN10	EXT_IN10	2	EXT_OUT10
3	EXT_IN11	EXT_IN11	4	EXT_OUT11
5	EXT_IN12	EXT_IN12	6	EXT_OUT12
7	EXT_IN13	EXT_IN13	8	EXT_OUT13
9	EXT_IN14	EXT_IN14	10	EXT_OUT14
11	EXT_IN15	EXT_IN15	12	EXT_OUT15
13	EXT_IN16	EXT_IN16	14	EXT_OUT16
15	EXT_IN17	EXT_IN17	16	EXT_OUT17
17	EXTG	EXTG	18	EXTG
19	+24Ve	EXT +24Vin	20	+24Ve

6. I/O interface diagram

6.1 Input diagram

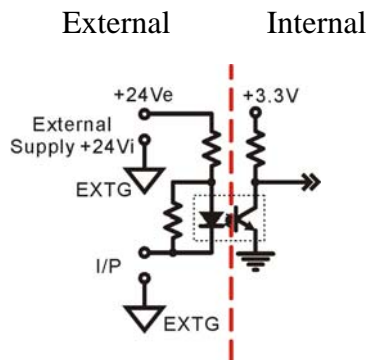

6.2 Output diagram (On main card)

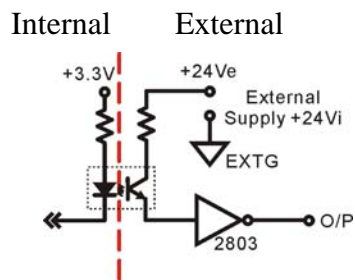

7. Hardware settings

7.1 CARD ID setting

Since PCI cards have plug and play function, the card ID is required for programmer to identify which card he/she will control without knowing the physical address assigned by the Windows. A 4 bits DIP switch or rotary switch for distinguishing the 16 identical card.

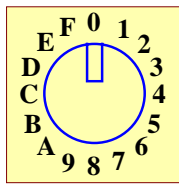

The following example sets the card ID at 12.

Example for card ID setting



Rotary switch set at ID=0

7.2 Jumper setting

Output relay contact type setting (JP4)	
	
Reset output after hot reset	Keep output after hot reset

8. Applications

- Accept : -- P.B./M.S./EMG./Contact- Start/Stop/Limit switch/sensor
 - Interlock/selective Sw.- Proximity switch
 - Aux. contact of transducer/detector
- As I/O of S/W PLC Controller
- Industrial ON/OFF control

9. Ordering information

<u>PRODUCT</u>	<u>DESCRIPTIONS</u>
DIO-3216B	32-channel Digital I/O Card for 16 DI and 16 DO Photo-coupler isolated
ADP-9201DIN(R)	DIN rail mounted wiring board with 16 I/O LED indicators and relay output for 8 DI, 8DO
ADP-9201DIN(S)	DIN rail mounted wiring board with 16 I/O LED indicators and SSR output for 8 DI, 8DO
ADP-9201DIN(P)	DIN rail mounted wiring board with 16 I/O LED indicators and PMOS output for 8 DI, 8DO
JD50053	DIN rail mounted dummy wiring board
M23207	20-pin flat cable 1.5 M
M23209	20-pin flat cable 3.0 M